



KBG121500 12V 150Ah(10hr)

Gel battery shows some distinctive advantages over flooded battery or AGM battery, such as super thermal stability, high deep discharge capability, good recovery from deep discharge, even if the battery is left discharged for three days, it will recover to 100% of capacity. With the above-mentioned advantages, the gel battery has long service life, specially suitable for motive power applications, such as golf trailer, sruubber, folklift, etc. The deep discharge cycles increased 50% as compared with the AGM battery.

Battery Construction

Component	Positive plate	Negative plate	Container	Cover	Safety valve	Terminal	Separator	Electrolyte
Raw material	Lead dioxide	Lead	ABS	ABS	Rubber	Copper	PVC	Gelled acid

General Features

- Nanometer SiO₂ and H₂SO₄ gelled electrolyte technology for efficiency gas recombination of up to 99% and freedom from electrolyte maintenance or water adding.
- Not restricted for air transport-complies with IATA/ICAO Special Provision A67.
- UL-recognized component.
- Can be mounted in any orientation.
- Computer designed lead, calcium tin alloy grid for high power density.
- Long service life, float or cyclic applications.
- Maintenance-free operation.
- Low self discharge.
- Case and cover available in both standard and flame retardant ABS.

Dimensions and Weight

Length(mm / inch)	530 / 20.87
Width(mm / inch)	209 / 8.23
Height(mm / inch)	215 / 8.46
Total Height(mm / inch)	220 / 8.66
Approx. Weight(Kg / lbs)	54.5 / 120

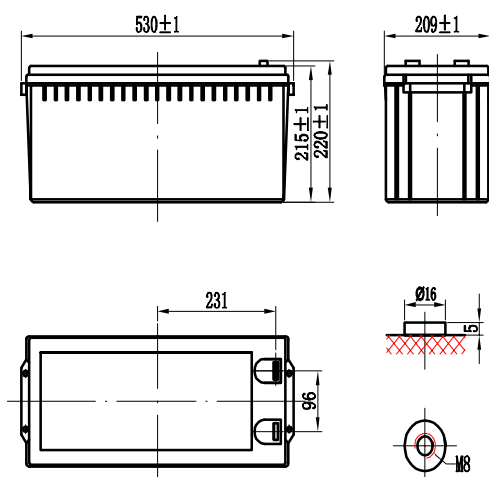

Performance Characteristics

Nominal Voltage	12V
Number of cell	6
Design Life	12 years
Nominal Capacity 77°F(25°C)	
10 hour rate (15.0A, 10.8V)	150Ah
5 hour rate (26.4A, 10.5V)	132Ah
1 hour rate (93A, 9.6V)	93Ah
Internal Resistance	
Fully Charged battery 77°F(25°C)	5.8mOhms
Self-Discharge	
2% of capacity declined per month at 20°C(average)	
Operating Temperature Range	
Discharge	-20~60°C
Charge	-10~60°C
Storage	-20~60°C
Max. Discharge Current 77°F(25°C)	750A(5s)
Short Circuit Current	2600A
Charge Methods: Constant Voltage Charge 77°F(25°C)	
Cycle use	2.30-2.35VPC
Maximum charging current	45.0A
Temperature compensation	-20mV/°C
Standby use	2.23-2.27VPC
No charge current limit is required	
Temperature compensation	-30mV/°C

Discharge Constant Current (Amperes at 77°F25°C)

End point volts/cell	10min	15min	30min	1h	3h	5h	10h	20h
1.60V	315	258	150	93.0	39.0	28.5	15.8	8.40
1.65V	297	240	147	90.0	38.0	27.6	15.6	8.25
1.70V	279	228	144	87.0	37.0	27.0	15.3	8.10
1.75V	261	210	141	84.0	36.5	26.4	15.2	8.03
1.80V	243	192	135	79.5	35.0	25.5	15.0	7.88

Discharge Constant Power (Watts at 77°F25°C)

End point volts/cell	10min	15min	30min	1h	3h	5h	10h	20h
1.60V	539	438	281	174	73.0	54.7	30.5	16.5
1.65V	513	434	268	166	69.3	51.7	28.8	15.6
1.70V	500	416	256	159	65.7	49.2	27.2	14.9
1.75V	476	390	248	153	62.5	48.2	26.2	14.4
1.80V	451	369	238	146	58.8	44.9	24.5	13.9

(Note)The above characteristics data are average values obtained within three charge/discharge cycles not the minimum values.

